



# MEGA HEX PAR

## User Manual

©2023 ADJ Products, LLC all rights reserved. Information, specifications, diagrams, images, and instructions herein are subject to change without notice. ADJ Products, LLC logo and identifying product names and numbers herein are trademarks of ADJ Products, LLC. Copyright protection claimed includes all forms and matters of copyrightable materials and information now allowed by statutory or judicial law or hereinafter granted. Product names used in this document may be trademarks or registered trademarks of their respective companies and are hereby acknowledged. All non-ADJ Products, LLC brands and product names are trademarks or registered trademarks of their respective companies.

**ADJ Products, LLC** and all affiliated companies hereby disclaim any and all liabilities for property, equipment, building, and electrical damages, injuries to any persons, and direct or indirect economic loss associated with the use or reliance of any information contained within this document, and/or as a result of the improper, unsafe, insufficient and negligent assembly, installation, rigging, and operation of this product.

**ADJ PRODUCTS LLC World Headquarters**

6122 S. Eastern Ave. | Los Angeles, CA 90040 USA

Tel: 800-322-6337 | Fax: 323-582-2941 | [www.adj.com](http://www.adj.com) | [lsupport@adj.com](mailto:lsupport@adj.com)

**ADJ Supply Europe B.V.**

Junostraat 2 | 6468 EW Kerkrade | Netherlands

Tel: +31 45 546 85 00 | Fax: +31 45 546 85 99 | [www.americandj.eu](http://www.americandj.eu) | [service@americandj.eu](mailto:service@americandj.eu)

**Europe Energy Saving Notice**

Energy Saving Matters (EuP 2009/125/EC)

Saving electric energy is a key to help protecting the environment. Please turn off all electrical products when they are not in use. To avoid power consumption in idle mode, disconnect all electrical equipment from power when not in use. Thank you!

**DOCUMENT VERSION**



Due to additional product features and/or enhancements, an updated version of this document may be available online.

Please check [www.adj.com](http://www.adj.com) for the latest revision/update of this manual before beginning installation and/or programming.

Date	Document Version	Software Version	DMX Channels	Notes
10/19/2017	1	1.00	6/7/8/11/12	Initial Release
02/03/2021	1.2	1.01	No Change	Primary/Secondary Update
12/15/2022	1.3	N/C	No Change	Updated UC IR & Airstream IR Remote Control; revised format
06/19/2023	1.4	N/C	No Change	Removed Airstream IR Information

# CONTENTS

<b>Introduction</b>	<b>4</b>
<b>Limited Warranty (USA Only)</b>	<b>5</b>
<b>Warranty Registration   Features   Installation</b>	<b>6</b>
<b>Safety Precautions</b>	<b>7</b>
<b>System Menu</b>	<b>9</b>
<b>Operating Instructions</b>	<b>11</b>
<b>DMX Set Up</b>	<b>14</b>
<b>DMX Traits</b>	<b>16</b>
<b>Color Macro Chart</b>	<b>19</b>
<b>Primary-Secondary Configuration   Multiple Unit Power Linking</b>	<b>20</b>
<b>UC IR Control</b>	<b>21</b>
<b>Dimmer Curve Chart</b>	<b>22</b>
<b>Fuse Replacement   Trouble Shooting   Cleaning</b>	<b>23</b>
<b>Dimensional Drawings</b>	<b>24</b>
<b>Specifications</b>	<b>25</b>

# INTRODUCTION

**Introduction:** The ADJ Mega Hex Par is a DMX intelligent, high powered LED par fixture that can be used in either a stand alone set up or connected in a Primary/Secondary set up. This fixture has five operating modes: Sound Active mode, Auto Run mode, RGBWA+UV Dimmer mode, Static Color mode, and DMX control. To optimize the performance of this product, please read these operating instructions carefully in order to familiarize yourself with the basic operations of this unit. These instructions contain important safety information regarding the use and maintenance of this unit. Please keep this manual with the unit, for future reference.

**Unpacking:** Every device has been thoroughly tested and has been shipped in perfect operating condition. Carefully check the shipping carton for damage that may have occurred during shipping. If the carton is damaged, carefully inspect the device for damage, and be sure all accessories necessary to install and operate the device have arrived intact. In the event that damage has been found or parts are missing, please contact our customer support team for further instructions. Please do not return this device to your dealer without first contacting customer support. Please do not discard the shipping carton in the trash. Please recycle whenever possible.

**Parts:** To purchase parts online visit:

<http://parts.adj.com> (US)

<http://www.adjparts.eu> (EU)

**ADJ SERVICE USA** - Monday - Friday 8:00am to 4:30pm PST

Voice: 800-322-6337 | Fax: 323-582-2941 | [support@adj.com](mailto:support@adj.com)

**ADJ SERVICE EUROPE** - Monday - Friday 08:30 to 17:00 CET

Voice: +31 45 546 85 60 | Fax: +31 45 546 85 96 | [support@adj.eu](mailto:support@adj.eu)

## **ADJ PRODUCTS LLC USA**

6122 S. Eastern Ave. Los Angeles, CA. 90040

323-582-2650 | Fax 323-532-2941 | [www.adj.com](http://www.adj.com) | [info@adj.com](mailto:info@adj.com)

## **ADJ SUPPLY Europe B.V**

Junostraat 2 6468 EW Kerkrade, The Netherlands

+31 (0)45 546 85 00 | Fax +31 45 546 85 99

[www.americandj.eu](http://www.americandj.eu) | [info@americandj.eu](mailto:info@americandj.eu)

## **ADJ PRODUCTS GROUP Mexico**

AV Santa Ana 30 Parque Industrial Lerma, Lerma, Mexico 52000

+52 (728) 282-7070

**WARNING!** To prevent or reduce the risk of electrical shock or fire, do not expose this unit to rain or moisture.

**CAUTION!** There are no user serviceable parts inside this unit. Do not attempt any repairs yourself, as doing so will void your manufacturer's warranty. In the unlikely event your unit may require service, please contact ADJ Products, LLC.

# LIMITED WARRANTY (USA ONLY)

- A. ADJ Products, LLC hereby warrants, to the original purchaser, ADJ Products, LLC products to be free of manufacturing defects in material and workmanship for a prescribed period from the date of purchase (see specific warranty period on reverse). This warranty shall be valid only if the product is purchased within the United States of America, including possessions and territories. It is the owner's responsibility to establish the date and place of purchase by acceptable evidence, at the time service is sought.
- B. For warranty service, you must obtain a Return Authorization number (RA#) before sending back the product-please contact ADJ Products, LLC Service Department at 800-322-6337. Send the product only to the ADJ Products, LLC factory. All shipping charges must be pre-paid. If the requested repairs or service (including parts replacement) are within the terms of this warranty, ADJ Products, LLC will pay return shipping charges only to a designated point within the United States. If the entire instrument is sent, it must be shipped in its original package. No accessories should be shipped with the product. If any accessories are shipped with the product, ADJ Products, LLC shall have no liability whatsoever for loss of or damage to any such accessories, or for the safe return thereof.
- C. This warranty is void if the serial number has been altered or removed; if the product is modified in any manner which ADJ Products, LLC concludes, after inspection, affects the reliability of the product, if the product has been repaired or service by anyone other than ADJ Products, LLC factory unless prior written authorization was issued to purchaser by ADJ Products, LLC; if the product is damaged because not properly maintained as set forth in the instruction manual.
- D. This is not a service contract, and this warranty does not include maintenance, cleaning or periodic check up. During the period specified above, ADJ Products, LLC will replace defective parts at its expense with new or refurbished parts, and will absorb all expenses for warranty service and repair labor by reason of defects in material or workmanship. The sole responsibility of ADJ Products, LLC under this warranty shall be limited to the repair of the product, or replacement thereof, including parts, at the sole discretion of ADJ Products, LLC. All products covered by this warranty were manufactured after August 15, 2012, and bear identifying marks to that effect.
- E. ADJ Products, LLC reserves the right to make changes in design and/or improvements upon its products without any obligation to include these changes in any products theretofore manufactured.
- F. No warranty, whether expressed or implied, is given or made with respect to any accessory supplied with products described above. Except to the extent prohibited by applicable law, all implied warranties made by ADJ Products, LLC in connection with this product, including warranties of merchantability or fitness, are limited in duration to the warranty period set forth above. And no warranties, whether expressed or implied, including warranties of merchantability or fitness, shall apply to this product after said period has expired. The consumer's and/or Dealer's sole remedy shall be such repair or replacement as is expressly provided above; and under no circumstances shall ADJ Products, LLC be liable for any loss or damage, direct or consequential, arising out of the use of, or inability to use, this product.
- G. This warranty is the only written warranty applicable to ADJ Products, LLC Products and supersedes all prior warranties and written descriptions of warranty terms and conditions heretofore published.

## LIMITED WARRANTY PERIODS

- **Non L.E.D. Lighting Products = 1-year (365 days) Limited Warranty** (Such as: Special Effect Lighting, Intelligent Lighting, UV lighting, Strobes, Fog Machines, Bubble Machines, Mirror Balls, Par Cans, Trussing, Lighting Stands etc. excluding LED and lamps)
- **Laser Products = 1 Year (365 Days) Limited Warranty** (excludes laser diodes which have 6 month limited warranty)
- **L.E.D. Products = 2-year (730 days) Limited Warranty** (excluding batteries which have a 180 day limited warranty)  
Note: 2 Year Warranty only applies to purchases within the United States.
- **StarTec Series = 1 Year Limited Warranty** (excluding batteries which have a 180 day limited warranty)
- **ADJ DMX Controllers = 2 Year (730 Days) Limited Warranty**

# WARRANTY REGISTRATION

The Mega Hex Par carries a 2 year limited warranty. Please fill out the enclosed warranty card to validate your purchase. All returned service items whether under warranty or not, must be freight pre-paid and accompany a return authorization (R.A.) number. The R.A. number must be clearly written on the outside of the return package. A brief description of the problem as well as the R.A. number must also be written down on a piece of paper included in the shipping carton. If the unit is under warranty, you must provide a copy of your proof of purchase invoice. You may obtain a R.A. number by contacting our customer support team on our customer support number. All packages returned to the service department not displaying a R.A. number on the outside of the package will be returned to the shipper.

## FEATURES

- Multi-Colors
- Five Operating Modes
- Electronic Dimming 0-100%
- Built in Microphone
- DMX-512 protocol
- 3-Pin DMX Connection
- Five DMX Modes: 6-, 7-, 8-, 11-, and 12-channel modes
- ADJ UC IR compatible
- Multiple Unit Power Linking (see **Multi Unit Power Linking** section of this manual)

## INSTALLATION

The unit should be mounted using a mounting clamp (not provided), and affixing it to the mounting bracket that is provided with the unit. Always ensure that the unit is firmly fixed to avoid vibration and slipping during operation. Always ensure that the structure to which you are attaching the unit is secure and is able to support at least 10 times the unit's weight. Also, always use a safety cable that can hold 12 times the weight of the unit when installing the fixture.

The equipment must be installed by a professional, and it must be installed in a place where it is out of the reach of general public's grasp.

# SAFETY PRECAUTIONS

- To reduce the risk of electrical shock or fire, do not expose this unit rain or moisture
- Do not spill water or other liquids into or on to your unit.
- Do not attempt to operate this unit if the power cord has been frayed or broken.
- Do not attempt to remove or break off the ground prong from the electrical cord. This prong is used to reduce the risk of electrical shock and fire in the event of an internal short.
- Disconnect from main power before making any type of connection.
- Do not remove the cover for any reason. There are no user serviceable parts inside.
- Never operate this unit with the cover removed.
- Never plug this unit in to a dimmer pack
- Always be sure to mount this unit in an area that will allow proper ventilation. Allow about 6” (15cm) between this device and a wall.
- Do not attempt to operate this unit if it has been damaged in any way.
- This unit is intended for indoor use only, and use of this product outdoors voids all warranties.
- During long periods of non-use, disconnect the unit’s main power.
- Always mount this unit in safe and stable matter.
- Power-supply cords should be routed so that they are not likely to be walked on or pinched by items placed upon or against them, paying particular attention to the point they exit from the unit.
- Cleaning - The fixture should be cleaned only as recommended by the manufacturer. See the **Cleaning** section of this manual for details.
- Heat - The appliance should be situated away from heat sources such as radiators, heat registers, stoves, or other appliances (including amplifiers) that produce heat.
- The fixture should be serviced by qualified service personnel when:
  - A. The power-supply cord or the plug has been damaged.
  - B. Objects have fallen, or liquid has been spilled into, the fixture.
  - C. The fixture has been exposed to rain or water.
  - D. The fixture does not appear to operate normally or exhibits a marked change in performance.
  - E. The fixture has fallen and/or subjected to extreme handling.

# SAFETY PRECAUTIONS



**HIGH  
INTENSITY  
ULTRAVIOLET  
LIGHT**

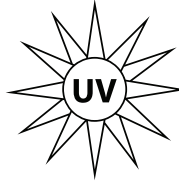

**AVOID DIRECT EYE & SKIN EXPOSURE.  
WEAR PROPER EYE & SKIN PROTECTION.  
SEE MANUAL FOR SAFETY INSTRUCTIONS.**

**RISK GROUP 3 - RISK OF EXPOSURE TO ULTRAVIOLET (UV) RADIATION!**

**FIXTURE EMITS HIGH INTENSITY ULTRAVIOLET (UV) LIGHT FROM THE UV LED.**

**WEAR PROPER EYE AND SKIN PROTECTION.**

**AVOID PROLONGED PERIODS OF EXPOSURE TO THE UV LED.**

**AVOID WEARING WHITE COLOR CLOTHING AND/OR USING (UV) PAINTS ON SKIN.**

**AVOID DIRECT EYE AND/OR SKIN EXPOSURE AT DISTANCES SHORTER THAN 11 feet (3.3m).**

**DO NOT OPERATE FIXTURE WITH DAMAGED OR MISSING EXTERNAL COVER.**

**DO NOT LOOK DIRECTLY INTO THE (UV) LIGHT AND/OR VIEW (UV) LIGHT DIRECTLY WITH OPTICAL INSTRUMENTS THAT MAY CONCENTRATE THE LIGHT/RADIATION OUTPUT.**

**INDIVIDUALS SUFFERING FROM A RANGE OF EYE CONDITIONS, SUNLIGHT EXPOSURE DISORDERS, OR INDIVIDUALS USING PHOTSENSITIVE MEDICATION, MAY EXPERIENCE DISCOMFORT IF EXPOSED TO THE ULTRAVIOLET (UV) LIGHT EMITTED FROM THIS FIXTURE.**



# SYSTEM MENU

MODE	SET UP	UP/DOWN	DESCRIPTION
<b>DMX Mode</b>	Address	d001 ~ d512	Set DMX starting address
	Channels	Ch06	Select DMX channel mode
		Ch07	
		Ch08	
		Ch11	
		Ch12	
	No DMX Mode	blAc	When DMX signal is lost or interrupted, unit switches all LEDs off
		LASt	When DMX signal is lost or interrupted, unit holds last state before signal was lost
ProG		When DMX signal is lost or interrupted, unit will run internal program	
nAnU		When DMX signal is lost or interrupted, the unit will default to manual setting	
Delay Mode	dr-0 ~ dr-4	Select delay mode	
<b>SEcd Mode</b>	SEcd Mode	SEcd	Set unit to secondary mode
<b>Dimmer Mode</b>	Red dimmer	r000 ~ r255	Adjust red color intensity
	Green dimmer	G000 ~ G255	Adjust green color intensity
	Blue dimmer	b000 ~ b255	Adjust blue color intensity
	White dimmer	U000 ~ U255	Adjust white color intensity
	Amber dimmer	A000 ~ A255	Adjust amber color intensity
	UV dimmer	u000 ~ u255	Adjust UV intensity
	Flash	FS00 ~ FS15	Adjust flash speed; 00 is off, 01 is slowest, 15 is fastest
<b>Sound Mode</b>	Mode select	So01 ~ So16	Select from 16 built in sound modes
	Sensitivity select	SJ-1 ~ SJ-8	Adjust sound sensitivity; 1 is lowest level and 8 is highest level
<b>Auto Run Mode</b>	Color Fade Mode	AF01 ~ AF16	Select from 16 color fade modes
	Color Change Mode	AJ01 ~ AJ16	Select from 16 color change modes
	Color Fade & Color Change	A-JF	Color fade and color changes modes run in a continuous cycle
	Speed Set	SP01 ~ SP16	Adjust speed of cycle
<b>Static Color Select Mode</b>	Color Select	CL00 ~ CL63	Select from the built-in static colors
	Flash	FS00 ~ FS15	Adjust flash speed; FS00 is off, FS01 is slowest, FS15 is fastest

CONTINUED ON NEXT PAGE

# SYSTEM MENU

MODE	SET UP	UP/DOWN	DESCRIPTION
<b>Other Mode</b>	Display on/off	don	Display screen always stays on
		doff	Display screen off
	IR Remote Function on/off	Iron	IR remote function on
		Irof	IR remote function off
	Display normal/inverse	Stnd	Display screen standard orientation
		rEv	Display screen inverted orientation
	Initialization mode	dEFA	Restore unit to factory settings

# OPERATING INSTRUCTIONS

**LED Display On/Off:** To set the LED display to turn off after 10 seconds of inactivity, press the MODE button until “don” is displayed, then press the UP button to scroll to “doff”. Now the display will disappear after 10s of inactivity. Press any button to turn the display on again.

- “don” = LED display on at all times.
- “doFF” = LED display shuts off after 10 seconds of inactivity.

**LED Display Inversion:** Flip the display 180° so that the display can be read upside down.

1. Plug the fixture in and press the MODE button until either “Stnd” or “rEv” is displayed. “Stnd” sets the display in standard orientation, while “rEv” inverts the display.
2. Press the UP or DOWN buttons to toggle between the two options.
3. Press ENTER to confirm the option that you want to use.

**Operating Modes:** The Mega HEX Par has five operating modes:

- *DMX control mode* - This function will allow you to control each individual fixture’s traits with a standard DMX 512 controller.
- *RGBWA + UV Mode* - Choose one of the six colors to remain static, or adjust the intensity of each color to make a custom color.
- *Sound-Active mode* - The unit will react to sound, chasing through the built in programs. There are 16 sound active modes.
- *Auto Mode* - There are 33 Auto Modes to choose from: 16 color fade modes, 16 color change modes, and 1 combination mode.
- *Static Color Mode* - There are 63 colors to choose from.

## **Static Color Mode:**

1. Plug the fixture in and press the MODE button until “CLXX” is displayed.
2. There are 63 colors to choose from. Select your desired color by pressing the UP and DOWN buttons, then press ENTER to confirm.
3. Next, activate strobing by pressing the SET UP button to enter the Flash (strobe) mode. “FS.XX” will be displayed, indicated that the unit is in Flash mode. The Flash can be adjusted between “FS.00” (flash off) to “FS.15” (fastest flash).

**Sound Active Mode:** In this mode the Mega HEX Par will react to sound, and chase through the different colors.

1. Plug the fixture in and press the MODE button until “SoXX” is displayed. “XX” represents the sound active mode (1-16) that is currently selected. Use the UP and DOWN buttons to scroll through the sound active modes.
2. After you have found your desired sound active mode, press the SET UP button to adjust the sound sensitivity. “SJ-X” will be displayed. Use the UP and DOWN buttons to adjust the sensitivity. “SJ-1” is the lowest sensitivity, and “SJ-8” is the highest.

# OPERATING INSTRUCTIONS

**DMX Mode:** Operating through a DMX controller gives the user the freedom to create custom programs tailored to their own individual needs. The Mega HEX Par has 5 DMX modes: 6 Channel mode, 7 Channel mode, 8 Channel mode, 11 Channel mode, and a 12 Channel mode.

1. To run your fixture in DMX mode, press the MODE button until “d.XXX” is displayed. “XXX” represents the currently selected address. Use the UP or DOWN buttons to select your desired DMX address, then press the SETUP button to select your DMX Channel mode.
2. Use the UP or DOWN buttons to scroll through the DMX Channel modes. Detailed information can be found in the **DMX Traits** section of this manual. The Channel modes are listed below:
  - *Ch06* for 6-channel mode.
  - *Ch07* for 7-channel mode
  - *Ch08* for 8-channel mode
  - *Ch11* for 11-channel mode
  - *Ch12* for 12-channel mode
3. After you have chosen your desired DMX Channel mode, connect the fixture to any standard DMX controller via the XLR connections.

## **RGBWA + UV Dimmer Mode:**

1. Plug the fixture in and press the MODE button until “r.XXX” is displayed. This indicates that the fixture is in Red dimming mode.
2. Press the UP and DOWN buttons to adjust intensity. After you have finished adjusting the intensity, or if you would like to skip to the next color, press the SET UP button.
3. When “G.XXX” is displayed, the fixture is in Green dimming mode. Press the UP and DOWN buttons to adjust intensity.
4. When “b.XXX” is displayed, the fixture is in Blue dimming mode. Press the UP and DOWN buttons to adjust intensity.
5. When “U.XXX” is displayed, the fixture is in White dimming mode. Press the UP and DOWN buttons to adjust intensity.
6. When “A.XXX” is displayed, the fixture is in Amber dimming mode. Press the UP and DOWN buttons to adjust intensity.
7. When “u.XXX” is displayed, the fixture is in UV dimming mode. Press the UP and DOWN buttons to adjust intensity.
8. After you have adjusted the colors as desired, you can then activate strobing by pressing the SET UP button to enter the strobe mode.
9. “FS.XX” will be displayed, indicating that the fixture is in strobe mode. The strobe can be adjusted between “00” (flash off) to “15” (fastest flash).

**Auto Run Mode:** There are 3 types of Auto Run Modes to choose from: Color Fade, Color Change, and both modes running together. The running speed is adjustable in all 3 modes.

1. Plug the fixture in and press the MODE button until either “AFXX”, “AJXX”, or “A-JF” is displayed. Press the SET UP Button to change between the 3 Auto Run modes.
  - *AFXX* = Color Fade mode, with 16 programs to choose from.
  - *AJXX* = Color Change mode, with 16 programs to choose from.
  - *A-JF* = Both Color Fade and Color Change modes running.
2. After selecting your desired mode, use the UP and DOWN buttons to scroll through the available programs. Note that this step is not applicable when running both modes together (option A-JF).
3. Press the SET UP button until “SP.XX” is displayed. Now adjust the running speed of your desired program. Use the UP or DOWN button to adjust the speed between “SP.01” (slowest) and “SP.16” (fastest). Press the SET UP button to return to your desired Auto Run Mode.

# OPERATING INSTRUCTIONS

**ADJ Remote Activation:** This function is used to activate or deactivate the IR sensor. When this function is activated, the fixture can be controlled using the ADJ UC IR. Please see the **IR Remote Control** section of this manual for detailed information.

1. Plug the fixture in and press the MODE button until “dXX” is displayed. “XX” represents either “on” or “oF”.
2. Press the SET UP button until “lrXX” is displayed. “XX” represents either “on” or “oF”.
3. Press the UP or DOWN buttons to either activate (“lrOn”) or deactivate (“lrOf”) the remote function.

**DMX State:** This mode defines how the fixture will behave in the event that the DMX signal is lost or interrupted, or the mode it will default to when power is first connected.

1. Plug the fixture in and press the MODE button until “d.XXX” is displayed. “XXX” represents the currently selected DMX address.
2. Press the SET UP button so that “nodn” is displayed. Use the UP and DOWN buttons to scroll through the DMX states.
  - “bLAC” (Blackout) - The unit will automatically go into stand by mode.
  - “LAsT” (Last State) - The unit will stay in the last DMX set up.
  - “ProG” (Auto Run) - The unit will automatically go into Auto Run mode.
  - “nAnU” - The unit will automatically go into RGBA+UV dimmer mode.
3. Use the UP and DOWN buttons to find the desired DMX state, then press SET UP to confirm and exit.

## **Dimmer Curve Setting:**

1. Plug the fixture in and press the MODE button until “d.XXX” is displayed, then press the SET UP button until “dr-X” is displayed. “X” represents a number between 0-4.
2. There are 5 dimmer curve settings to choose from. Please see the **Dimmer Curve Chart** section of this manual for the settings and their respective beginning and ending fade times.

**Default Running Mode:** This returns all modes to their default settings.

1. Plug the fixture in and press the MODE button until “dXX” is displayed. “XX” represents either “on” or “oFF”.
2. Press the SET UP button until “dEFA” is displayed.
3. Press the UP and DOWN buttons simultaneously. Press the MODE button to exit.

# DMX SET UP

**Power Supply:** The Mega Hex Par contains an automatic voltage switch, which will automatically sense the voltage when it is plugged into the power source. With this switch there is no need to worry about the correct power voltage, and this unit can be plugged in almost anywhere.

**DMX-512:** DMX is short for Digital Multiplex. This is a universal protocol used as a form of communication between intelligent fixtures and controllers. A DMX controller sends DMX data instructions from the controller to the fixture. DMX data is sent as serial data that travels from fixture to fixture via the DATA “IN” and DATA “OUT” XLR terminals located on all DMX fixtures (most controllers only have a DATA “OUT” terminal).

**DMX Linking:** DMX is a language allowing all makes and models of different manufacturers to be linked together and operate from a single controller, as long as all fixtures and the controller are DMX compliant. To ensure proper DMX data transmission, try to use the shortest path possible when linking several DMX fixtures. The order in which fixtures are connected in a DMX line does not influence the DMX addressing. For example, a fixture assigned a DMX address of 1 may be placed anywhere in a DMX line: at the beginning, at the end, or anywhere in the middle. When a fixture is assigned a DMX address of 1, the DMX controller knows to send DATA assigned to address 1 to that unit, no matter where it is located in the DMX chain.

**Data Cable (DMX Cable) Requirements (For DMX Operation):** This fixture can be controlled via DMX-512 protocol, and features 5 selectable DMX channel modes. The DMX address is set using the controls and display screen on the back panel. Your unit and DMX controller require standard 3-pin XLR connectors for data input and output (Figure 1). If you are making your own cables, be sure to use standard 110-120 Ohm shielded cable (This cable may be purchased at almost all pro lighting stores). Your cables should be made with a male XLR connector at one end and a female XLR connector at the other. Also remember that DMX cable must be daisy chained and cannot be split.



Figure 1

# DMX SET UP

**Special Note: Line Termination.** When longer runs of cable are used, you may need to use a terminator on the last unit to avoid erratic behavior. A terminator is a 110-120 ohm 1/4 watt resistor which is connected between pins 2 and 3 of a male XLR connector (DATA + and DATA -). This unit is inserted in the female XLR connector of the last unit in your daisy chain to terminate the line. Using a cable terminator (ADJ part number Z-DMX/T) will decrease the possibilities of erratic behavior.

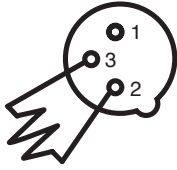

Termination reduces signal errors and avoids signal transmission problems and interference. It is always advisable to connect a DMX terminal, (Resistance 120 Ohm 1/4 W) between PIN 2 (DMX-) and PIN 3 (DMX +) of the last fixture.

Figure 4

**5-Pin XLR DMX Connectors.** Some manufacturers use 5-pin DMX-512 data cables for DATA transmission in place of 3-pin. 5-pin DMX fixtures may be implemented in a 3-pin DMX line by using a cable adaptor. These adaptors are readily available at most electric stores. The chart below details a proper cable conversion.

3-Pin XLR to 5-Pin XLR Conversion		
Conductor	3-Pin XLR Female (Out)	5-Pin XLR Male (In)
Ground/Shield	Pin 1	Pin 1
Data Compliment (- signal)	Pin 2	Pin 2
Data True (+ signal)	Pin 3	Pin 3
Not Used		Do Not Use
Not Used		Do Not Use

# DMX TRAITS

CHANNEL					DMX VALUES	FUNCTION
6CH	7CH	8CH	11CH	12CH		
1	1	1	1	1	000 - 255	<b>Red</b> , 0% to 100%
2	2	2	2	2	000 - 255	<b>Green</b> , 0% to 100%
3	3	3	3	3	000 - 255	<b>Blue</b> , 0% to 100%
4	4	4	4	4	000 - 255	<b>White</b> , 0% to 100%
5	5	5	5	5	000 - 255	<b>Amber</b> , 0% to 100%
6	6	6	6	6	000 - 255	<b>UV</b> , 0% to 100%
	7	7	7	7	000 - 255	<b>Master Dimmer</b> , 0% to 100%
						<b>Strobing</b>
					000 - 031	LED Off
					032 - 063	LED On
					064 - 095	Strobing, slow to fast
		8	8	8	096 - 127	LED On
					128 - 159	Pulse Strobing, slow to fast
					160 - 191	LED On
					192 - 223	Random Strobing, slow to fast
					224 - 255	LED On
						<b>Program Selection Mode</b>
			9	9	000 - 051	Dimming Mode
					052 - 102	Color Macro Mode
					103 - 153	Color Change Mode
					154 - 204	Color Fade Mode
					205 - 255	Sound Active Mode
						<b>Color Macros/Programs</b>
					000 - 255	<b>Color Macro Mode</b> , see <b>Color Macro Chart</b> section of this manual
						<b>Color Change Programs</b>
					000 - 015	Color Change 1
					016 - 031	Color Change 2
					032 - 047	Color Change 3
			10	10	048 - 063	Color Change 4
					064 - 079	Color Change 5
					080 - 095	Color Change 6
					096 - 111	Color Change 7
					112 - 127	Color Change 8
					128 - 143	Color Change 9
					144 - 159	Color Change 10
					160 - 175	Color Change 11
					176 - 191	Color Change 12

CONTINUED ON NEXT PAGE



# DMX TRAITS

CHANNEL					DMX VALUES	FUNCTION
6CH	7CH	8CH	11CH	12CH		
						<b><i>Color Change Programs (continued)</i></b>
					192 - 207	Color Change 13
					208 - 223	Color Change 14
					224 - 239	Color Change 15
					240 - 255	Color Change 16
						<b><i>Color Fade Programs</i></b>
					000 - 015	Color Fade 1
					016 - 031	Color Fade 2
					032 - 047	Color Fade 3
					048 - 063	Color Fade 4
					064 - 079	Color Fade 5
					080 - 095	Color Fade 6
					096 - 111	Color Fade 7
					112 - 127	Color Fade 8
					128 - 143	Color Fade 9
					144 - 159	Color Fade 10
					160 - 175	Color Fade 11
			10	10	176 - 191	Color Fade 12
					192 - 207	Color Fade 13
					208 - 223	Color Fade 14
					224 - 239	Color Fade 15
					240 - 255	Color Fade 16
						<b><i>Sound Active Programs</i></b>
					000 - 015	Sound Active Mode 1
					016 - 031	Sound Active Mode 2
					032 - 047	Sound Active Mode 3
					048 - 063	Sound Active Mode 4
					064 - 079	Sound Active Mode 5
					080 - 095	Sound Active Mode 6
					096 - 111	Sound Active Mode 7
					112 - 127	Sound Active Mode 8
					128 - 143	Sound Active Mode 9
					144 - 159	Sound Active Mode 10
					160 - 175	Sound Active Mode 11
					176 - 191	Sound Active Mode 12
					192 - 207	Sound Active Mode 13

CONTINUED ON NEXT PAGE

# DMX TRAITS

CHANNEL					DMX VALUES	FUNCTION	
6CH	7CH	8CH	11CH	12CH			
			10	10		<b><i>Sound Active Programs (continued)</i></b>	
						208 - 223	Sound Active Mode 14
						224 - 239	Sound Active Mode 15
						240 - 255	Sound Active Mode 16
			11	11		<b><i>Program Speed / Sound Sensitivity</i></b>	
						000 - 255	<b><i>Program Speed</i></b> , slow to fast
						000 - 255	<b><i>Sound Sensitivity</i></b> , least to most sensitive
			12	12		<b><i>Dimmer Curves</i></b>	
						000 - 020	Standard
						021 - 040	Stage
						041 - 060	TV
						061 - 080	Architectural
						081 - 100	Theatre
						101 - 255	Default to factory settings

## NOTES:

### *11Ch Mode:*

- When Channel 9 is between the values of 0-51, Channels 1-6 are used, and Channel 8 will control strobing.
- When Channel 9 is between the values of 52-102, Channel 10 is in Color Macros Mode, and Channel 8 will control strobing.
- When Channel 9 is between the values of 103-153, Channel 10 is in Color Change Mode, and Channel 11 will control the color change speed.
- When Channel 9 is between the values of 154-204, Channel 10 is in Color Fade Mode, and Channel 11 will control the color fade speed.
- When Channel 9 is between the values of 205-255, Channel 10 is in Sound Active Mode, and Channel 11 will control the sound sensitivity.

### *12Ch Mode:*

- When Channel 9 is between the values of 0-51, Channels 1-6 are used, and Channel 8 will control strobing.
- When Channel 9 is between the values of 52-102, Channel 10 is in Color Macros Mode, and Channel 8 will control strobing.
- When Channel 9 is between the values of 103-153, Channel 10 is in Color Change Mode, and Channel 11 will control the color change speed.
- When Channel 9 is between the values of 154-204, Channel 10 is in Color Fade Mode, and Channel 11 will control the color fade speed.
- When Channel 9 is between the values of 205-255, Channel 10 is in Sound Active Mode, and Channel 11 will control the sound sensitivity.

# COLOR MACRO CHART

DMX VALUES	COLORS
000 - 003	Off
004 - 007	Red
008 - 011	Green
012 - 015	Blue
016 - 019	White
020 - 023	Amber
024 - 027	UV
028 - 031	R+G
032 - 035	R+B
036 - 039	R+W
040 - 043	R+A
044 - 047	R+UV
048 - 051	G+B
052 - 055	G+W
056 - 059	G+A
060 - 063	G+UV
064 - 067	B+W
068 - 071	B+A
072 - 075	B+UV
076 - 079	W+A
080 - 083	W+UV
084 - 087	A+UV
088 - 091	R+G+B
092 - 095	R+G+W
096 - 099	R+G+A
100 - 103	R+G+UV
104 - 107	R+G+W
108 - 111	R+B+A
112 - 115	R+B+UV
116 - 119	R+W+A
120 - 123	R+W+UV
124 - 127	R+A+UV

DMX VALUES	COLORS
128 - 131	G+B+W
132 - 135	G+B+A
136 - 139	G+B+UV
140 - 143	G+W+A
144 - 147	G+W+UV
148 - 151	G+A+UV
152 - 155	B+W+A
156 - 159	B+W+UV
160 - 163	B+A+UV
164 - 167	W+A+UV
168 - 171	R+G+B+W
172 - 175	R+G+B+A
176 - 179	R+G+B+UV
180 - 183	R+G+W+A
184 - 187	R+G+W+UV
188 - 191	R+G+A+UV
192 - 195	R+B+W+A
196 - 199	R+B+W+UV
200 - 203	R+B+A+UV
204 - 207	R+W+A+UV
208 - 211	G+B+W+A
212 - 215	G+B+W+UV
216 - 219	G+B+A+UV
220 - 223	G+W+A+UV
224 - 227	B+W+A+UV
228 - 231	R+B+B+W+A
232 - 235	R+G+B+W+UV
236 - 239	R+G+B+A+UV
240 - 243	R+G+W+A+UV
244 - 247	R+B+W+A+UV
248 - 251	G+B+W+A+UV
252 - 255	R+G+B+W+A+UV

# PRIMARY - SECONDARY CONFIGURATION

These units can be linked together to run in a primary-secondary setup, in which one unit will act as the controlling unit and the others will react to the controlling unit's built-in programs. Any unit can act as a primary or as a secondary, but only one unit in a linked system can be programmed to act as the primary.

## Primary-Secondary Connections and Settings:

1. Daisy chain your units via the XLR connectors on the rear of each unit. Use standard XLR data cables to link your units together. Remember that the male XLR connector is the input, and the female XLR connector is the output. The first unit in the chain (primary) will use the female XLR connector only, while the last unit in the chain will use the male XLR connector only.
2. Connect the first secondary unit to the primary.
3. Set the primary unit to your desired mode of operation. On each of the secondary units, press the MODE button until "SEcd" is displayed. The "SEcd" unit(s) will now follow the "Primary".

# MULTIPLE UNIT POWER LINKING

The fixtures can be linked together using the IEC input and output sockets. The maximum number of units that can be linked in this manner is as follows:

- **20 fixtures @ 120V**
- **36 fixtures @ 240V**

After reaching the maximum number of linked fixtures, a new power outlet will be required in order to accommodate additional fixtures.

***Note: Use caution when linking fixtures of other make and model types, as the power consumption of other fixture models may exceed the power rating of this device!***

# UC IR CONTROL

The **UC IR** infrared remote gives you control of various functions, as described below. The fixture's infrared sensor must first be activated as described in in **Operating Instructions** section of this manual, and the remote must be aimed at the front of the fixture. Maximum range is 30 feet. Please note that the fixture only responds to the remote when the fixture is set to primary mode.

- **STAND BY** - Pressing this button will blackout the fixture. Press the button again will turn the fixture back on.
- **FULL ON** - Press this button down to fully light up the unit. Press this button again to return the unit to its last mode of operation.
- **FADE/GOBO** - This button activates fade mode.
- **"DIMMER +" and "DIMMER -"** - Use these buttons to adjust the output intensity.
- **STROBE** - Press this button to activate strobing. Use buttons 1-4 to adjust the strobe speed, where "1" is the slowest strobe speed and "4" is the fastest. Press this button again to stop strobing.
- **COLOR** - Press this button to activate color mode. Use buttons 1-9 to find your desired color.
- **1-9** - Use buttons 1-9 to select your desired color when color mode is active, or your desired program when show mode is active. Use buttons 1-4 to select you desired strobe rate when strobing is active.
- **SOUND ON & OFF** - Use the buttons to activate and deactivate sound active mode.
- **SHOW 0** - Press this button to activate show mode. Use buttons 1-9 to select your desired show. Press this button twice for show 10. Press button 1 twice for show 11.



# DIMMER CURVE CHART

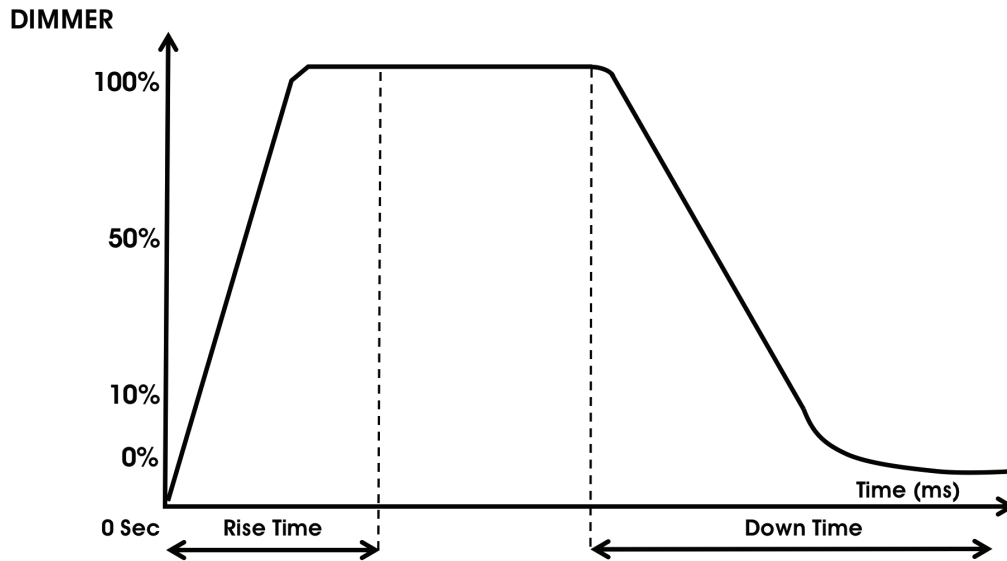

Dimming Curve Ramp Effect	0 sec Fade Time		1 sec Fade Time	
	Rise Time (ms)	Down Time (ms)	Rise Time (ms)	Down Time (ms)
Standard (default)	0	0	0	0
Stage	780	1100	1540	1660
TV	1180	1520	1860	1940
Architectural	1380	1730	2040	2120
Theatre	1580	1940	2230	2280

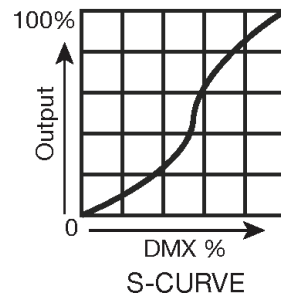
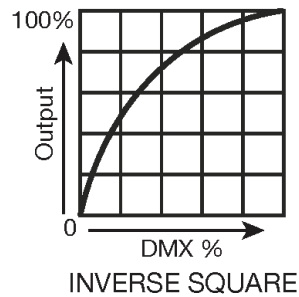
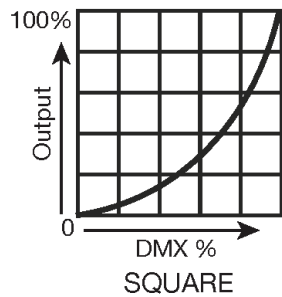
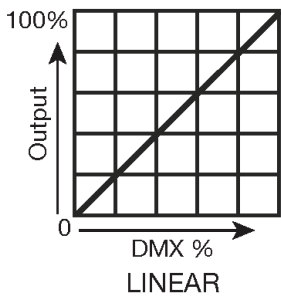

# FUSE REPLACEMENT

Disconnect the unit from its power source and remove the power cord. Find that the fuse holder is located inside the power socket, then insert a flat-head screw driver into the power socket and gently pry out the fuse holder. Remove the bad fuse and replace with a new fuse of the same rating. Please note that the fuse holder also has a holder for a spare fuse.

# TROUBLE SHOOTING

Listed below are a few common problems the user may encounter, with possible solutions.

## ***Unit not responding to DMX:***

Check that the DMX cables are connected and wired correctly (pin 3 is “hot”; on some other DMX devices pin 2 may be “hot”). Also, check that all cables are connected to the right connectors, as the manner in which the inputs and outputs are connected can affect operation of the unit.

## ***Unit does not respond to sound:***

- Quiet or high pitched sounds will not activate the unit.
- Make sure that Sound Active mode is enabled.

# CLEANING

Due to fog residue, smoke, and dust, cleaning of the internal and external optical lenses must be carried out periodically to optimize light output.

- Use normal glass cleaner and a soft cloth to wipe down the outside casing.
- Clean the external optics with glass cleaner and a soft cloth every 20 days.
- Always be sure to dry all parts completely before plugging the unit back in.

Cleaning frequency depends on the environment in which the fixture operates (i.e. smoke, fog residue, dust, dew).

# DIMENSIONAL DRAWINGS

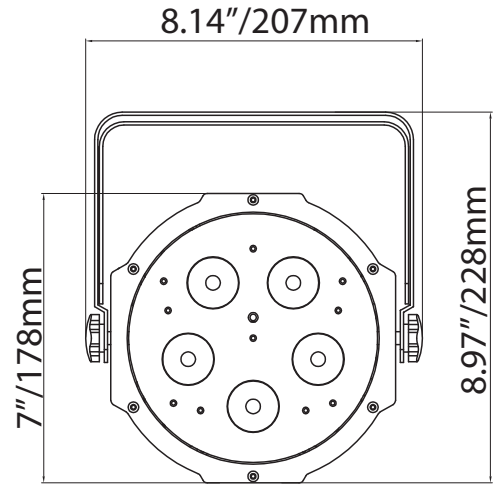
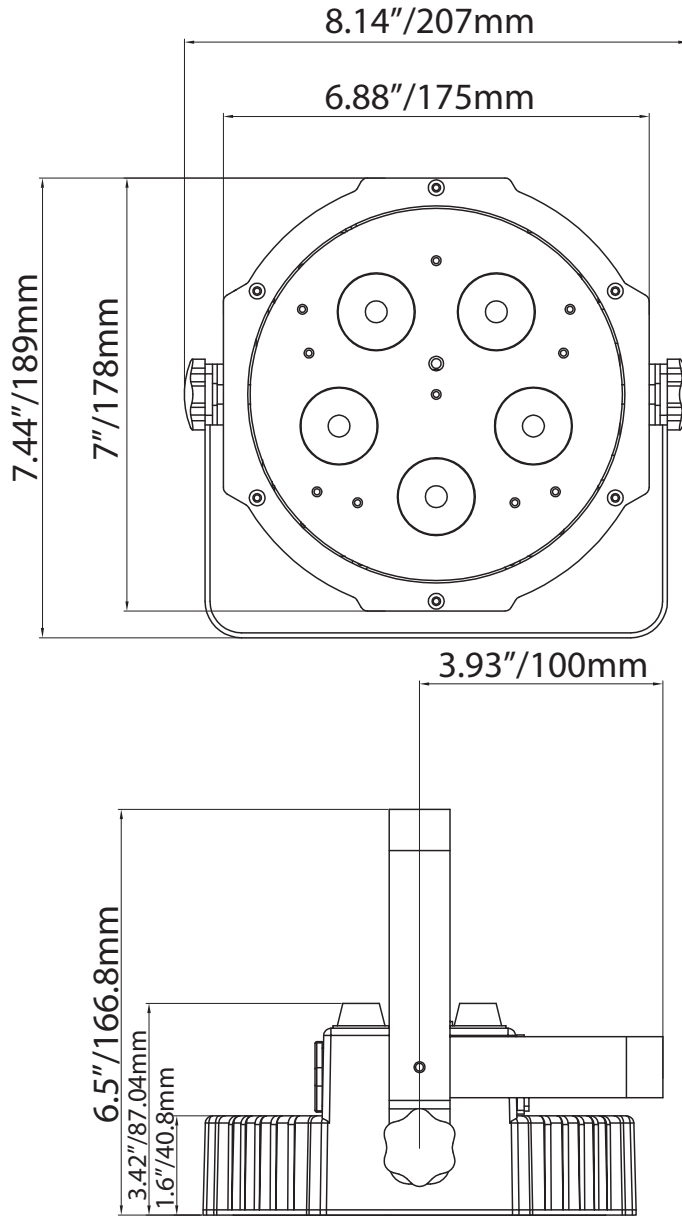



# SPECIFICATIONS

<b>Model:</b>	<b>Mega Hex Par</b>
<b>Voltage:</b>	100V ~ 240V / 50~60 Hz
<b>LEDs:</b>	5 x 6W 6-in-1 Hex LEDs
<b>UV Range:</b>	399-435 nm
<b>Beam Angle:</b>	25 degrees
<b>Working Position:</b>	Any safe working position
<b>Power Draw:</b>	30 W
<b>Power Linking:</b>	20 fixtures max @ 120V 36 fixtures max @ 240V
<b>Fuse:</b>	2A
<b>Weight:</b>	2.7 lbs / 1.22 kgs
<b>Dimensions:</b>	10.25" (L) x 10.25" (W) x 4.25" (H) 261mm (L) x 260mm (W) x 110mm (H)
<b>Colors:</b>	RGBWA+UV Color Mixing
<b>DMX Channels:</b>	5 DMX Modes - 6, 7, 8, 11, or 12 channels
<b>Warranty:</b>	2 Years (730 Days)



*Please Note: Specifications and improvements in the design of this unit and this manual are subject to change without any prior written notice.*

## Follow Us!



[Facebook.com/adjlighting](https://www.facebook.com/adjlighting)  
[YouTube.com/adjlighting](https://www.youtube.com/adjlighting)

[Twitter.com/adjlighting](https://twitter.com/adjlighting)  
[Instagram: adj\\_lighting](https://www.instagram.com/adj_lighting)

ADJ Products, LLC  
6122 S. Eastern Ave. Los Angeles, CA 90040 USA  
Tel: 323-582-2650 / Fax: 323-725-6100  
Web: [www.adj.com](http://www.adj.com) / E-mail: [info@adj.com](mailto:info@adj.com)

A.D.J. Supply Europe B.V.  
Junostraat 2  
6468 EW Kerkrade  
Netherlands

[service@adjgroup.eu](mailto:service@adjgroup.eu) / [www.americandj.eu](http://www.americandj.eu)  
Tel: +31 45 546 85 00 / Fax: +31 45 546 85 99

